

TTM-00BT series MULTIPOINT TEMPERATURE CONTROLLER

INSTRUCTION MANUAL

Thank you for purchasing this TOHO product. Please read this instruction manual and thoroughly familiarize yourself with the functions and characteristics of the product before use. Please retain this manual for future reference. Use most updated manual from nearest TOHO representative. Furthermore, please keep this instruction with you anytime while your operation and make sure that this instruction must be delivered to end users.

TOHO ELECTRONICS INC.
© All Rights Reserved

Refer to the following manual together with this instruction manual before operating this product.

- Model TTM-00BT Users manual (No. 44-4739)
- Contents of Package

The following are provided together in the same package.

- Model TTM-00BT : 1unit
- Instruction Manual : 1pce

Safety Precaution

Definition of warning symbol

	CAUTION	If make miss handling, in case of possible to get damage or physical damage.
--	----------------	--

Definition of physical damage is damage to house, property and animal so on.









Definition of symbol

	Prohibition of disassemble Possible to get electronic shock by disassemble of product.
---	---

	General Notice of prohibition on non specific.
---	---

	General Notice of warning, caution and danger on non specific.
---	---

Caution Symbol

	
Do not allow metal fragments or lead wire scraps to fall inside of this product. These may cause electric shock, fire or malfunction.	
Never disassemble, repair or modify the product. Doing so may cause electric shock, fire or malfunction.	
Use the product within the rated load. Not doing so may cause damage or burning.	
Use the product within the rated supply voltage. Not doing so may cause damage or burning.	
Be sure to tighten the terminal screw and the connectors rock securely. Not doing so may cause damage or malfunction.	
Correctly set the setting on this product matched to the control target. If the setting are not compatible with the control target, the product might operate in an unexpected manner, resulting in damage to the product or an accident.	
Tighten any terminal screw to torque (about 0.5 N/m). If screw is not tighten enough, this may cause fire or malfunction.	
To maintain safety in the event of a product malfunction, we recommend taking safety measures, for example, installing an excessive temperature rise prevention alarm on a separate line. If malfunction prevents control, this may result in a major accident.	

NOTICE

Be sure to observe these precautions to ensure safe use

- 1) Make sure that the rated voltage is attained within two seconds of turning the power ON.
- 2) To ensure correct temperature measurement, allow at least 30 minutes for the Unit to warm up.
- 3) When use of self turning, turn on temperature controller and load at same time or turn on load first.
- 4) Do not wire the terminals which are not used.
- 5) Be sure to wire properly with correct polarity of terminals.
- 6) Do not touch the mounted parts or the rear surface of PCBs. To hold this product, please hold ceiling, pole or edge.
- 7) In the time of installation, do not touch sharp edges such as electrical leads.
- 8) Connection of wiring
 - a) Crimp terminal: specified size (M3, width 6.9mm or below)
 - b) End soldered wire: use AWG 22 to 16 (Length of exposed wire: 5 to 7mm)
- 9) A switch or circuit breaker should be placed close to the unit and should be indicated properly.
- 10) To reduce induction noise, separate the high-voltage or large current power lines from other lines, and avoid parallel or connect wiring with the power lines when you are wiring to the terminal. We recommend the use of separating pipes, ducts, or shield lines.
- 11) Separate this product from machines generating powerful high frequency electromagnetic waves or surge, such as high frequency welding machines or high-frequency sewing machines.
- 12) When wiring signal lines of input/output with over 30m lines inside, put surge control circuit for preventing surge. When locating outside, set a surge control circuit regardless of the length of lines.
- 13) Do not place at the following locations.
 - a) Location with large electromagnetic effects
 - b) Location with sulfide gas or corrosive gas
 - c) Location with dust or oil smoke
 - d) Location with direct sunlight
 - e) Location with water splash
 - f) Location with a risk of icing.
 - g) Location with high voltage cable, welding machine and origin of generating electric noise.
 - h) Location with machines using high pressured igniter.
 - i) Location with excessive high humidity and where there is a risk of condensation
 - j) Location with mechanical vibration and shocks
 - k) Location with condensation as the result of severe changes in temperature.
 - l) Location with directly subject to heat radiated from heating equipment.
- 14) Location with temperature and humidity should be applicable with rated level, if necessary please force to cool down.
- 15) To allow heat dissipation, be sure not to obstruct the area around the product or ventilation ducts.

About communication initial setting This product is required to set initial setting of [Communication speed setting] and [Unit number setting]

- 1) [Communication speed setting] Setting by dip-switch (SW2).

1	2	Communication speed
OFF	OFF	4 8 0 0 bps
ON	OFF	9 6 0 0 bps
OFF	ON	1 9 2 0 0 bps
ON	ON	3 8 4 0 0 bps

Use dip-switch 1&2
(3&4 :Always OFF)
Combination will follow
*Default=[1:ON, 2:OFF(9600bps)]

- 2) [Unit number setting] Setting by rotary switch. Unit number set by 16 count (0 ~ F)

*Remark: Operate setting of [Communication speed setting] & [Unit number setting] definitely without power on.

Name and Function

- | | |
|---|---|
| 1) SW1:Unit number converter switch . . . 00 ~ 0F(16 count) | 11) LED2:Communication(-) · S D lamp(red) |
| 2) SW2:Communication converter switch . . . Communication speed setting | 12) LED3:Power lamp(green) |
| 3) CN1:Control output connector . . . NPN open corrector output 8points | 13) LED4 ~ 11:Alarm output lamp(red) |
| 4) CN2:Alarm output connector . . . NPN open corrector output 11points | 14) LED12:Heater Break alarm output lamp(red) |
| 5) CN3:CT input connector . . . CT input 8points | 15) LED13:Heater Short alarm output lamp(red) |
| 6) TB1:Thermocouple or R.T.D temperature input terminal | 16) LED14:Internal Error output lamp(red) |
| 7) TB2:Power voltage terminal (power voltage: DC24V+10%-15%) | 17) LED15 ~ 22:Control output lamp(orange) |
| 8) TB3:RS-232C or RS-485 of terminal for communication | |
| 9) TB4:Event input terminal (input voltage range: DC12 ~ 24V ± 10%) | |
| 10) LED1:Communication(+) · RD lamp(green) | |

Name and function of each parts

1) Product figure

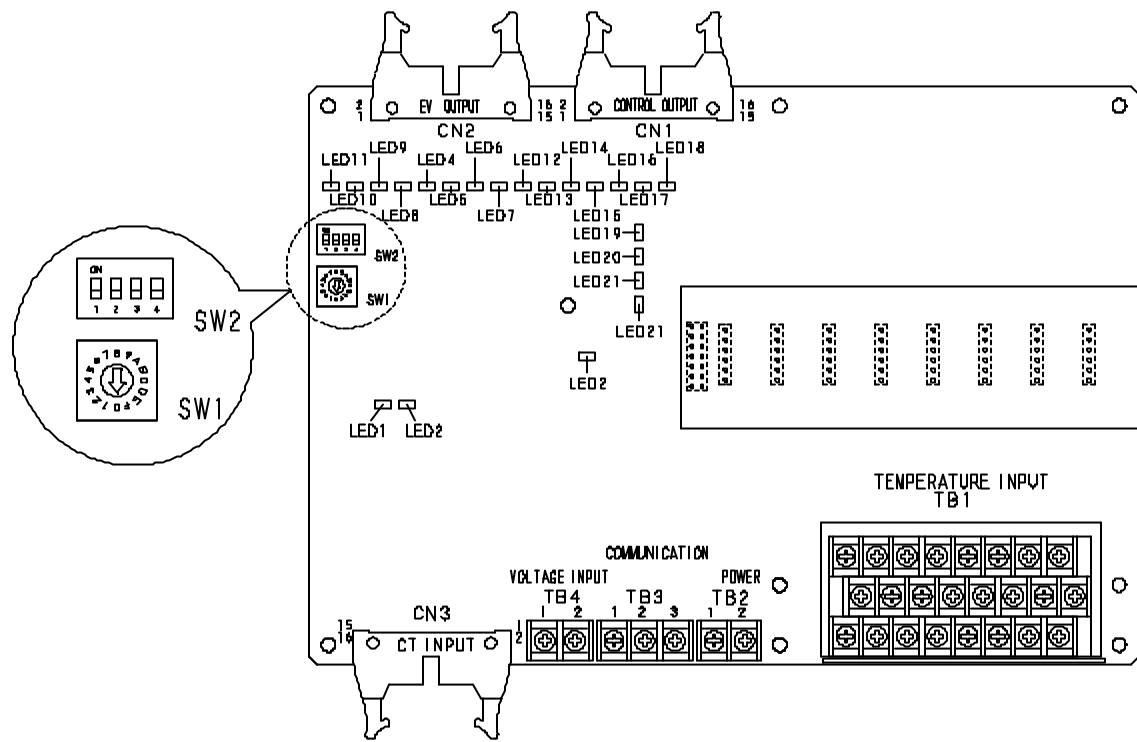

Installation

1) Dimension

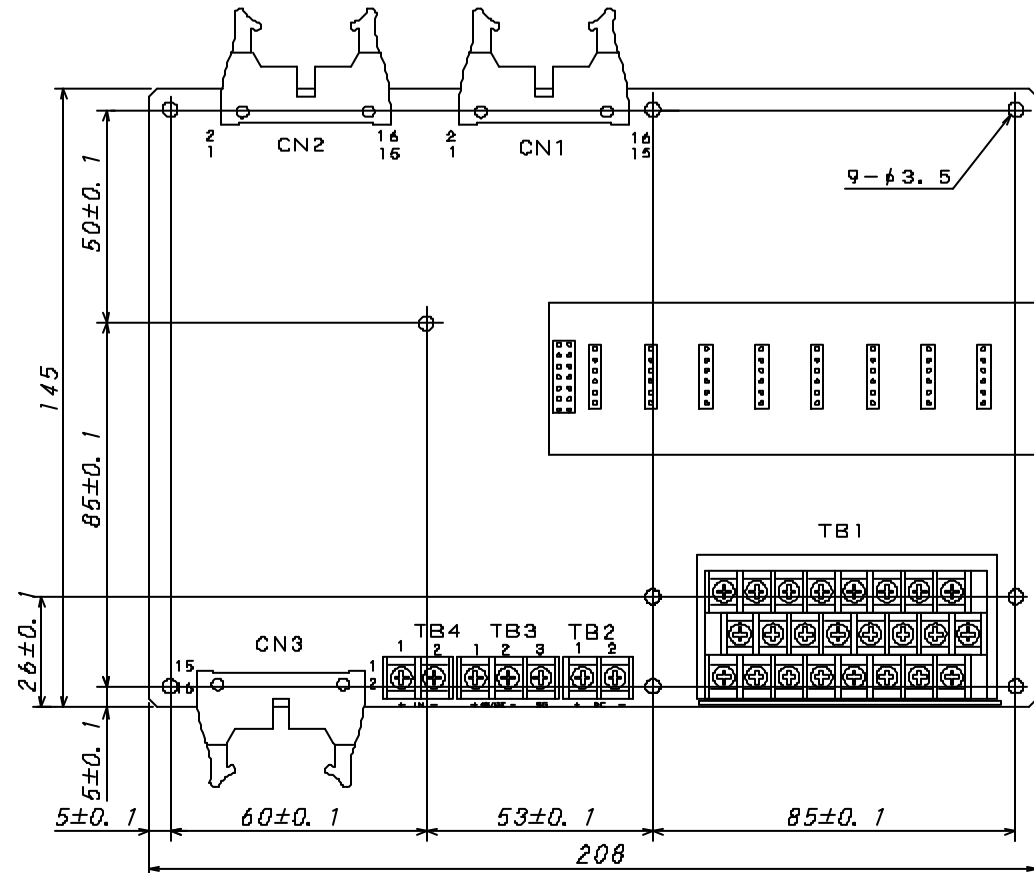

2) Installation method :

- Install 9 parts (φ3.5) by screw (M3) .
- Place horizontal or vertical with input terminal facing below.
- Install board with over 8mm upper by using spacer.
- For plural installation, keep 50mm distance from the other.

Wiring of Terminal

TB1 to TB4 : : Terminal table

1) Temperature input(TB1: terminal table):
Thermocouple input

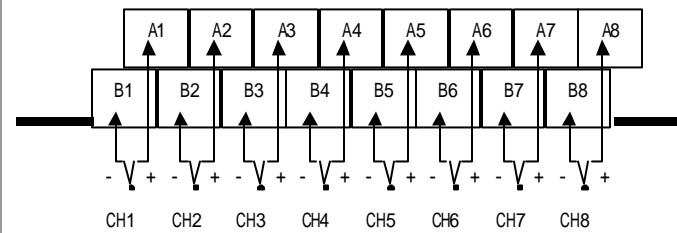

For wiring, use M3 round terminal, Y terminal & welding wire refer to mark on the terminal table for terminal number R.T.D input

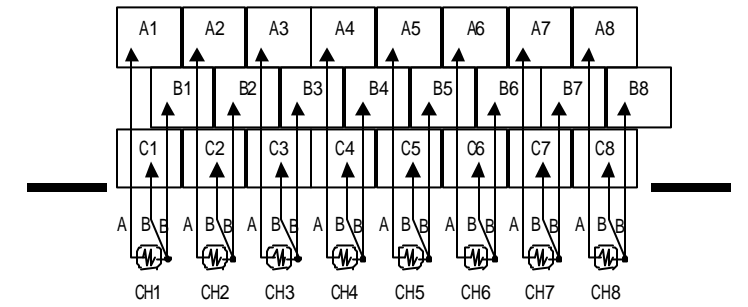

• When extend cable, use appropriate compensation lead wire • Use wire material with wire resistance value below 5 Ω/per wire for connecting RTD with main body.

2) Event input (TB4:terminal table)

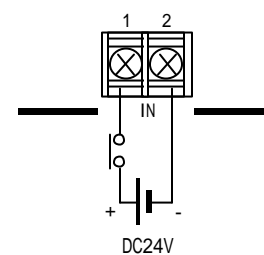

3) Communication(TB3:terminal table)

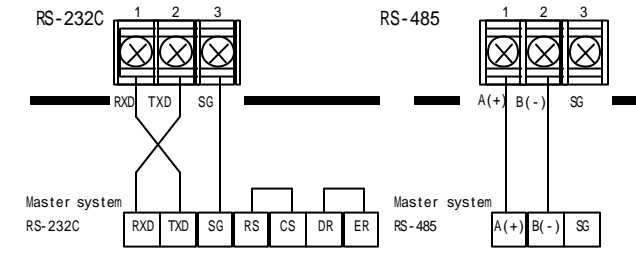

4) Power(TB2:terminal table)

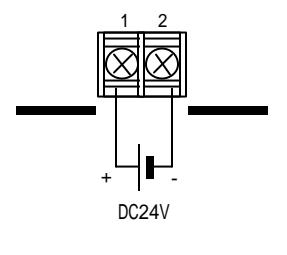

CN1 to CN3 :XG4A-1634 (OMRON)

(Figures describe connector on the board)

5) Alarm output (CN2:Connector)

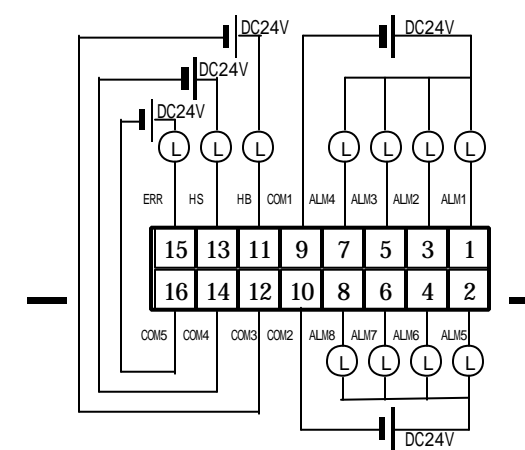

ALM1 to 8:Alarm output 1 to 8 HB: Heater Break Alarm output
HS: Heater Short Alarm output ERR: Internal Error output

6) Control output (CN1: connector)

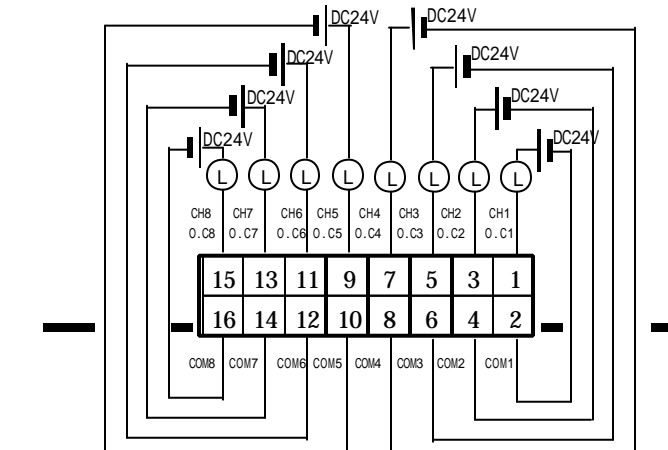

O.C1 to 8:Control output 1 to 8
COM1 to 8: Common

7) CT input (CN3: connector)

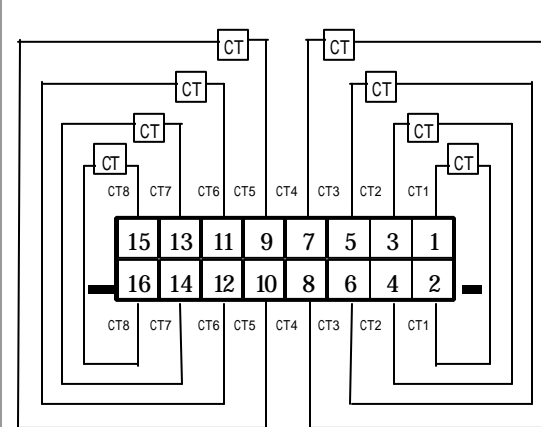

PRECAUTIONS IN USING THE PRODUCT

When the product is used under the circumstances or environment below, ensure adherence to limitations of the ratings and functions. Also, take countermeasures for safety precautions such as fail-safe installations.

- Use under circumstances or environment which are not described in the instruction manual.
- Use for nuclear power control, railway, aircraft, vehicle, incinerator, medical equipment, entertainment equipment, safety device etc...
- Use for applications where death or serious property damage is possible and extensive safety precautions are required.

TOHO ELECTRONICS INC.

Head Office 1-13-21 Tanashioda, Sagami-hara-shi, Kanagawa 229-1125 Japan
Tel: +81-42-777-3311, Fax: +81-42-777-3751
Tokyo Office The 3rd Wako Bldg, 7-17-6 Nishi-Shinjuku, Shinjuku-ku, Tokyo 160-0023, Japan
Tel: +81-3-3363-1331, Fax: +81-3-3363-3335
Osaka Office Yachiyo Bldg East Wing 7F, 2-Kita 1-21 Tenjinbashi, Kita-ku, Osaka-shi, Osaka 530-0041, Japan
Tel: +81-6-6353-9205, Fax: +81-6-6353-9273