

TOHO ELECTRONICS INC.

BOARD TYPE DIGITAL CONTROLLER **TTM-10L** SERIES INSTRUCTION MANUAL

Thank you for purchasing model TTM-10L series Digital Process Controller.

Please go through this Instruction Manual carefully and use the unit in proper manner.

1 . NOTICE/WARNING BEFORE USAGE

- When having the controller in hand, please confirm the correct model and optional function for your purchase. Please refer to "8. ORDERING INFORMATION" for details of model.
- The following symbol marks are used in this Instruction Manual for handling this model safely.

WARNING	In case of mishandling, serious dangers may occur to the operator such as death, electrocution and a skin burn.
----------------	---

CAUTION	In case of mishandling, it may cause some damages to the unit or the operator getting slight injury.
----------------	--

CAUTION

- Do not push the keys by sharp points for prevention of its malfunction.

WARNING

- Make sure the correct wiring connection before turning on electricity. Mis-wiring may cause malfunction of the unit and may cause a fire.
- Never remodel the unit to prevent malfunction of unit and fire.

2 . PARTS INDICATION

- | | |
|--------------------|---|
| 2.1 OPERATION KEYS | a) S W 1 : MODE key Change Each Mode/Parameter. |
| | b) S W 2 : Up key Up Setting Value or Change setting. |
| | c) S W 3 : Down key Down Setting Value or Change setting. |

3 . OUTER DIMENSIONS

3.1 OUTER DIMENSIONS

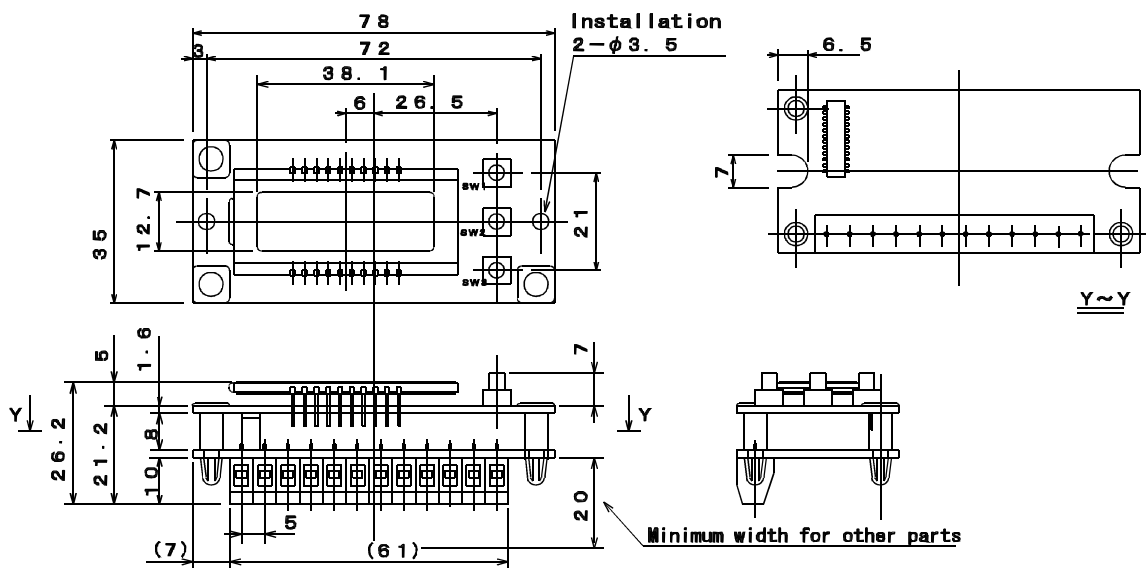

3.2 LOCATION OF THE UNIT SETTING

Install the unit at the following proper locations:-

- | | |
|---|---|
| <ul style="list-style-type: none"> a) Away from the gas of sulfide and corrosion. b) Less mechanical vibration and shock. c) Temperature and Humidity being within the limit of operation environment. d) Away from the direct sunshine and not to be exposed by wind and rain. e) Far away from the equipments using high-voltage ignition devices. f) Away from the influence of electromagnetic field. g) Away from High-Voltage wire, welding machine and the generator of electric noise. | <ul style="list-style-type: none"> h) Less dust and oily smoke. i) Away from the direct dampness or the flood with water. |
|---|---|

4 . WIRING METHOD

4.1 CHANGE OF POWER SUPPLY.

The change of Power supply is available to select with the following plugs a, b and c.

:Short circuit socket fixed to a and b.:12VDC

:Short circuit socket fixed to b and c.:24VDC

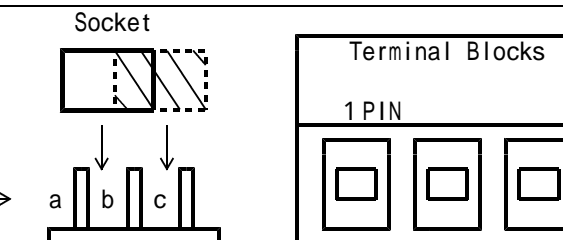
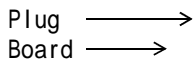

4.2 TERMINAL CONNECTION DRAWING

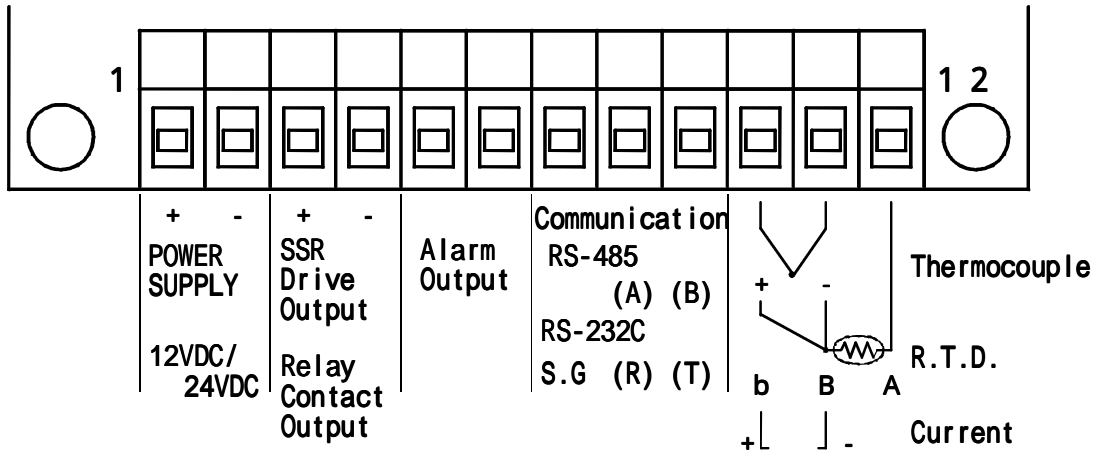

4.3 CAUTION FOR WIRING CONNECTION

- Wiring material with resistance less than 5 Ω per wire should be used to connect R.T.D. with this unit.
- The Specified extension lead wire or the wire itself should be used to connect thermocouple with this unit as wiring material.
- In case this unit should be used close to the noise generators, please use shield-wires.
- Please do not wire the Input/Output lines inside of the same duct and the pipes of electric wires.
- The signal wire of Input/Output should be away from power supply and loaded lines at least 50cm.

⚠ WARNING • For prevention of electric shock, please do wiring connection only after turning off Power.

⚠ CAUTION • This unit does not function for approx. 4 seconds after turning on Power. (No function at Output side)
 • For prevention of mis wiring, please make sure to confirm the name labels i.e. Input terminal and Power source terminal etc. beside the each wire.

5 . OPERATE FLOW AND PARAMETER INFORMATION

5.1 METHOD TO CHANGE EACH DISPLAY

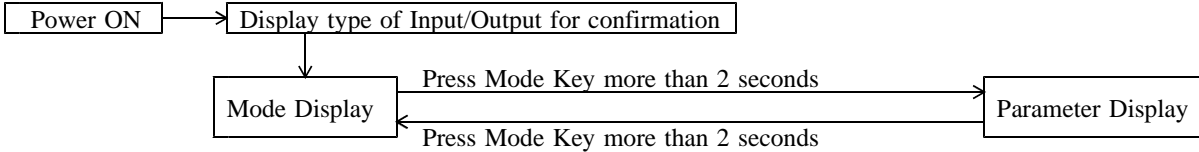

5.2 OPERATE FLOW

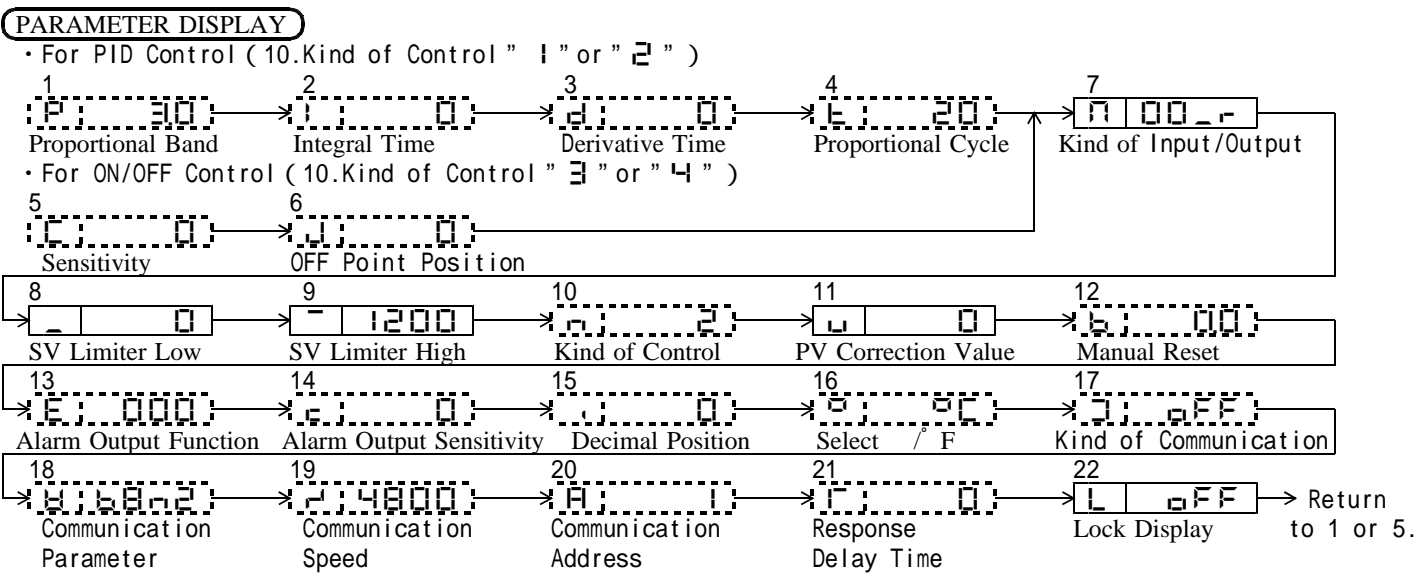
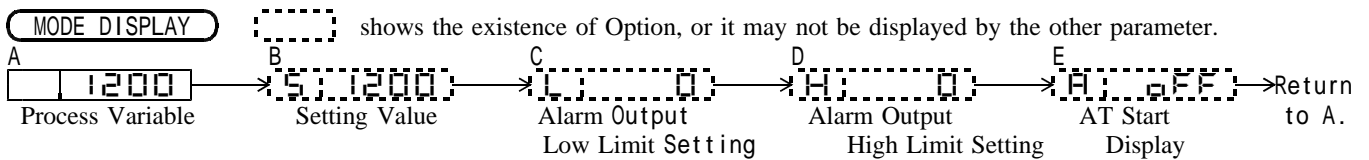

5.3 OTHER DISPLAY INDICATIONS

- : Shown whenever Input value exceeds the High limit of Display range, or the snapping of the Input line.
- : Shown whenever Input value exceeds the Low limit of Display range, or the snapping of the Input line at 4-20mA.
- E r r 0 : Shown for Memory error. Please contact us for repairing service.
- E r r 1 : Shown for A/D converter error. Please contact us for repairing service.
- E r r 2 : Shown for Auto-tuning error, Push any keys for resetting this display.
- L o C : Shown when Parameter being changed during Key lock.
- A t : Shown during Auto-tuning.

5.4 INFORMATIONS FOR EACH PARAMETER

• MODE Display

Character Indications	Descriptions	Initial Value	Display conditions & Remarks
A	Process Variable		Normal Display after the Input of Power
B	S Setting Value Setting range:SV Limiter Low (_) ~ SV Limiter High (¯) Setting unit :Thermocouple : 1 (° F) R.T.D. :1 / 0.1 (° F) Current : 1 / 0.1 / 0.01	0	Shown on PID or ON/OFF control .
C	L Alarm Output Setting Low Limit Setting range : Thermocouple : -1999 ~ 9999 R.T.D. : -199 ~ 999 / -199.9 ~ 999.9 Current : -1999 ~ 9999 / -199.9 ~ 999.9 / -19.99 ~ 99.99 Setting unit : Same as that of B.Setting Value.	0	Shown when Alarm Output is installed and set at Low Limit Alarm Output or High/Low Limit Alarm Output.
D	H Alarm Output Setting High Limit Setting range : Same as that of C.Alarm Output Setting Low Limit. Setting unit : Same as that of B.Setting Value.	0	Shown when Alarm Output is installed and set at High Limit Alarm Output or High/Low Limit Alarm Output.
E	A AT start display Press UP/DOWN key more than 2 seconds for start/reset of Auto-tuning.(AT) A : o r : Shown during AT. A : o F F : Shown without AT. NORMAL & A t : Shown alternatively during A T.	o F F	Shown on PID control.

PARAMETER DISPLAY

1	P Proportional Band Setting range : 0.1 ~ 200.0 Setting unit : 0.1%	30	Shown on PID control.																																
2	I Integral Time Setting range : 0 ~ 3600 Setting unit : 1 second	0	Shown on PID control. Integral operation OFF at I = 0																																
3	D Derivative Time Setting range : 0 ~ 3600 Setting unit : 1 second	0	Shown on PID control. Derivative operation OFF at D = 0																																
4	E Output Proportional Cycle Setting range : 1 ~ 120 Setting unit : 1 second	20	Shown on PID control.																																
5	C Output Sensitivity Setting range : Thermocouple : 0 ~ 9999 R.T.D. : 0 ~ 999 / 0.0 ~ 999.9 Current : 0 ~ 9999 / 0.0 ~ 999.9 / 0.00 ~ 99.99 Setting unit : Same as that of above B.Setting Value.	0	Shown on ON/OFF control.																																
6	L OFF point position Setting range : Same as that of above C.Alarm Output Setting Low Limit. Setting unit : Same as that of above B.Setting Value.	0	Displays at ON/OFF control.																																
7	A Kinds of INPUT/ OUTPUT <table border="1" style="display: inline-table; margin-right: 20px;"> <thead> <tr><th>**</th><th>Input Type</th></tr> </thead> <tbody> <tr><td>00</td><td>K thermocouple</td></tr> <tr><td>01</td><td>J thermocouple</td></tr> <tr><td>02</td><td>E thermocouple</td></tr> <tr><td>03</td><td>T thermocouple</td></tr> <tr><td>04</td><td>R thermocouple</td></tr> <tr><td>05</td><td>S thermocouple</td></tr> <tr><td>06</td><td>N thermocouple</td></tr> <tr><td>07</td><td>W5Re/W26Re</td></tr> </tbody> </table> <table border="1" style="display: inline-table; margin-right: 20px;"> <thead> <tr><th>**</th><th>Input Type</th></tr> </thead> <tbody> <tr><td>10</td><td>P t 1 0 0</td></tr> <tr><td>11</td><td>J P t 1 0 0</td></tr> <tr><td>20</td><td>4-20mA DC</td></tr> </tbody> </table> <table border="1" style="display: inline-table;"> <thead> <tr><th></th><th>Output Type</th></tr> </thead> <tbody> <tr><td>r</td><td>Relay contact output</td></tr> <tr><td>P</td><td>SSR Drive Output</td></tr> </tbody> </table>	**	Input Type	00	K thermocouple	01	J thermocouple	02	E thermocouple	03	T thermocouple	04	R thermocouple	05	S thermocouple	06	N thermocouple	07	W5Re/W26Re	**	Input Type	10	P t 1 0 0	11	J P t 1 0 0	20	4-20mA DC		Output Type	r	Relay contact output	P	SSR Drive Output	therm- ocouple INPUT 00 4-20mDC INPUT 20	The Kind of Output needs to be selected "r" or "P" before purchase. The following Input types are NOT selective. thermocouple 4-20mADC R.T.D 4-20mADC
**	Input Type																																		
00	K thermocouple																																		
01	J thermocouple																																		
02	E thermocouple																																		
03	T thermocouple																																		
04	R thermocouple																																		
05	S thermocouple																																		
06	N thermocouple																																		
07	W5Re/W26Re																																		
**	Input Type																																		
10	P t 1 0 0																																		
11	J P t 1 0 0																																		
20	4-20mA DC																																		
	Output Type																																		
r	Relay contact output																																		
P	SSR Drive Output																																		

8	- SV Limiter Low	For Thermocouple Input Setting range: Full scale range of SV, but the difference with (-) should be more than 50 (° F).	0	Shown at all cases.
		For R.T.D. Input Setting range: Full scale range of SV, but the difference with (-) should be more than 5.0 (° F).		
		For Current Input. Setting range: Full scale range of SV, but the difference with (-) should be more than 50 digit.		
9	- SV Limiter High	For Thermocouple Input Setting range: Full scale range of SV, but the difference with (-) should be more than 50 (° F).	1200	Shown at all cases.
		For R.T.D. Input Setting range: Full scale range of SV, but the difference with (-) should be more than 5.0 (° F).		
		For Voltage/Current Input. Setting range: Full scale range of SV, but the difference with (-) should be more than 50 digit.		
10	Kind of Control	1 : PID Control (Normal) 2 : PID Control (Reverse) 3 : ON/OFF Control (Normal) 4 : ON/OFF Control (Reverse)	2	During each control.
11	□ PV Correction Value	Setting range : Same as that of above C.Alarm Output Setting Low Limit. Setting unit : Same as that of above B.Setting Value.	0	Shown at all cases.
12	▢ Manual Reset	Setting range : 0.0 ~ 100.0 Setting unit : %	00	Shown on PID control.
13	E Alarm Output Function	<p> <input type="checkbox"/> * * * ADDITIONAL FUNCTIONS <input type="checkbox"/> None <input type="checkbox"/> Alarm output hold <input type="checkbox"/> Stand-by sequence <input type="checkbox"/> Alarm output hold +Stand-by sequence TYPE OF PV Alarm OUTPUT <input type="checkbox"/> None <input type="checkbox"/> Deviation high/low limit <input type="checkbox"/> Deviation high limit <input type="checkbox"/> Deviation low limit <input type="checkbox"/> Deviation high and low limit range <input type="checkbox"/> Absolute value high/low limit <input type="checkbox"/> Absolute value high limit <input type="checkbox"/> Absolute value low limit <input type="checkbox"/> Absolute value high and low limit range TYPE OF ABNORMAL Alarm OUTPUT <input type="checkbox"/> None <input type="checkbox"/> PV Abnormal Alarm output </p>	000	Shown at Alarm Output. PV Abnormal Output means : "OVER"display or "UNDER"display
14	▢ Alarm Output Sensitivity	Setting range : Same as that of above 5.Output Sensitivity. Setting unit : Same as that of above B.Setting Value.	0	Shown at Alarm Output.
15	▣ Decimal Position	R.T.D. : 0 / 00 Current : 0 / 00 / 000	0	Shown at Current or R.T.D. Input.
16	▢ / °F Change	0C . . . 0F . . . ° F	0C	Shown at Thermocouple or R.T.D. Input.
17	□ Kind of Communica- tion	RS-232C 0FF : OFF 232C : RS-232C RS-485 0FF : OFF 485 : RS-485	0FF	Shown at either of Communications.

18	Communication parameter	<table border="1"> <tr> <td colspan="2">BCC CHECK</td> <td colspan="2">DATA LENGTH</td> <td colspan="2">PARITY</td> <td colspan="2">STOP BIT</td> </tr> <tr> <td><input type="checkbox"/></td> <td>None</td> <td><input checked="" type="checkbox"/></td> <td>7 BITS</td> <td><input type="checkbox"/></td> <td>None</td> <td colspan="2">1</td> </tr> <tr> <td><input checked="" type="checkbox"/></td> <td>Yes</td> <td><input checked="" type="checkbox"/></td> <td>8 BITS</td> <td><input checked="" type="checkbox"/></td> <td>odd Number</td> <td colspan="2">2</td> </tr> <tr> <td colspan="4"></td> <td><input checked="" type="checkbox"/></td> <td>Even Number</td> <td colspan="2"></td> </tr> </table>	BCC CHECK		DATA LENGTH		PARITY		STOP BIT		<input type="checkbox"/>	None	<input checked="" type="checkbox"/>	7 BITS	<input type="checkbox"/>	None	1		<input checked="" type="checkbox"/>	Yes	<input checked="" type="checkbox"/>	8 BITS	<input checked="" type="checkbox"/>	odd Number	2						<input checked="" type="checkbox"/>	Even Number			6802	Displays at Communication.
BCC CHECK		DATA LENGTH		PARITY		STOP BIT																														
<input type="checkbox"/>	None	<input checked="" type="checkbox"/>	7 BITS	<input type="checkbox"/>	None	1																														
<input checked="" type="checkbox"/>	Yes	<input checked="" type="checkbox"/>	8 BITS	<input checked="" type="checkbox"/>	odd Number	2																														
				<input checked="" type="checkbox"/>	Even Number																															
19	Communication Speed	Communication Speed : 1200/2400/4800/9600BPS	4800	Same as above.																																
20	Communication Address	Setting range : 1 ~ 99	1	Displays at Communication.																																
21	Response Delay Time	Setting range : 0 ~ 250 Setting unit : mSEC	0	Displays at Communication.																																
22	Lock Setting	OFF . . . Lock OFF ALL . . . ALL Parameters Lock PrA . . . Parameter Display Lock ESU . . . Lock except SV	OFF	Display at all cases.																																

6 . PRECAUTION OF CONTROL

This unit uses a fixed memory device to memorize setting value. Therefore, the setting value remains in memory even after Power Off. At actual selection, please arrange to match the kind and initial setting of the sensor. For the setting of input kind, please refer to "Kinds of Input/Output in Parameter Display 7". This unit is able to control 2 types such as ON/OFF control and PID control(Time Proportional Control).

- PID CONTROL Advantage : Better result of control compared with ON/OFF Control.
Disadvantage: The life period of relay contact becomes short as it switches On and OFF so frequently.
- ON/OFF CONTROL Advantage : Generally, the life period of relay contact last longer as it switches ON at temperature increase and OFF at temperature decrease from the level of setting value.
Disadvantage: The result of control is not as good as PID Control.

As for the Setting of the KIND OF CONTROL, please select and set at the display of "KIND OF CONTROL"of "PARAMETER DISPLAY · 10".

PID CONTROL

The initial value for Parameter of "Proportional Band" set at " $P = 3.0$ ".
Though the control can be done by this initial setting, please do Auto-Tuning for getting better result of control. While Auto-tuning is operational the setting of all necessary parameters for each value (P , I , d) can be done automatically.
At the time of Auto-Tuning, set the unit to the condition of actual control by connecting heater and sensors. It may take a time to finalize Auto-tuning.
For start of Auto-tuning, please press key for more than 2 seconds at AT Start Display of "Mode Display E". After start up, Auto-tuning and Parameters Setting will be done automatically, and the control is to be started soon.

ON/OFF CONTROL

The parameter of sensitivity is set initially at " $C = 0$ ".
In case the sensitivity flutters at control, use larger parameter of sensitivity to stabilize the fluttering.

Due to the above procedure, the parameter can be set to match the unit to be controlled.

7 . DEFINITIONS AND FUNCTIONS

7.1 ADDITIONAL FUNCTIONS

- Stand-by Sequence . . . This is the function not to turn on Alarm Output even if it covers the conditions to activate Alarm Output at Power ON. This function is valid when the Power turns on at the part of a slanting line of the following Alarm Output Function Chart.
- Alarm Output Hold . . . This function holds the condition of Alarm Output after the Alarm Output has started to activate. For release of this function, make Power turn on again or setting the position of UNHOLD at Additional Function Setting.

7.2 ALARM OUTPUT PV

Alarm Output makes Alarm Output Relay ON/OFF as PV corresponds to Alarm Output PV.

- Alarm Output Function Chart

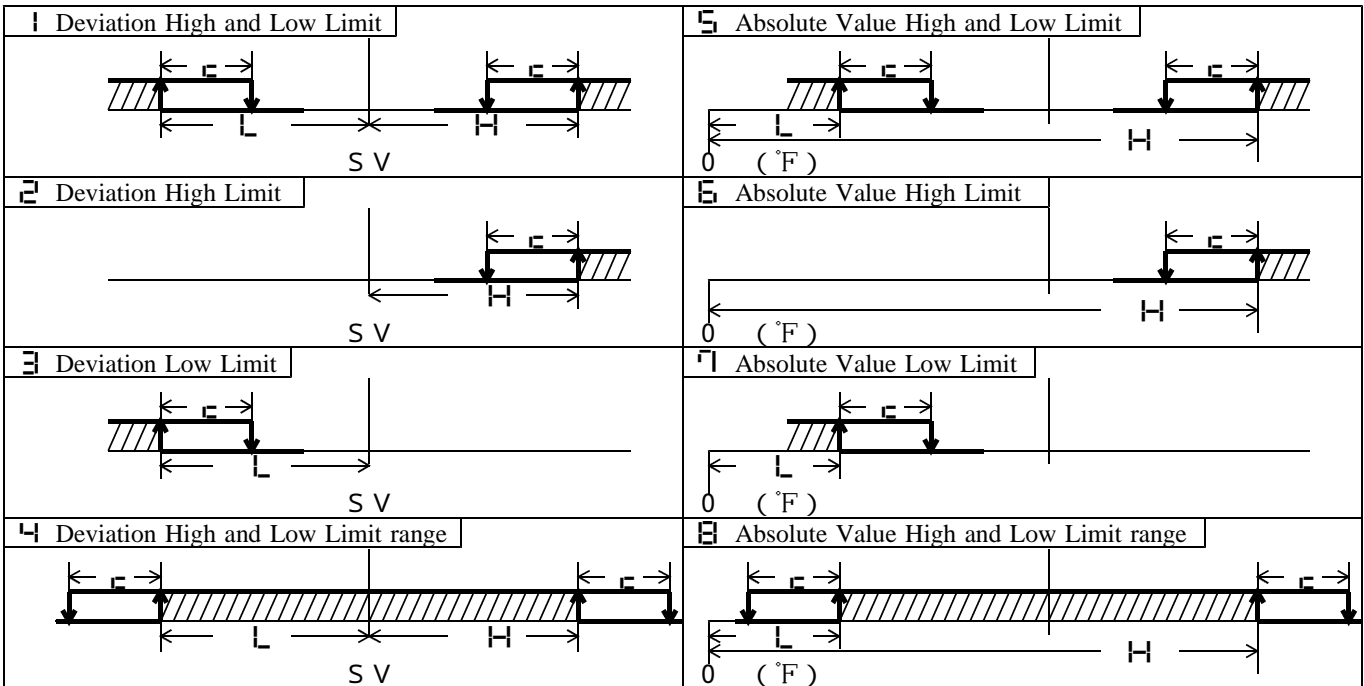

: Range of Alarm Output L : Alarm Output Setting Low Limit H : Alarm Output Setting High Limit
 c : Alarm Output sensitivity

7.3 INPUT DISPLAY RANGE AND SETTING RANGE

CHART 1 DISPLAY RANGE & SETTING RANGE OF THERMOCOUPLE INPUT (J I S C 1 6 0 2 - 1 9 9 5)

K	Setting Range	Display Range		Setting Range	Display Range
	°C	0 ~ 1 2 0 0	N	°C	0 ~ 1 3 0 0
	°F	0 ~ 2 2 0 0		°F	3 2 ~ 2 3 5 0
J	°C	0 ~ 8 0 0	W5Re/ W26Re	°C	0 ~ 2 3 0 0
	°F	0 ~ 1 4 5 0		°F	3 2 ~ 4 2 0 0
E	°C	0 ~ 8 0 0	R	°C	0 ~ 1 7 0 0
	°F	0 ~ 1 4 5 0		°F	3 2 ~ 3 1 0 0
T	°C	- 2 0 0 ~ 4 0 0	S	°C	0 ~ 1 7 0 0
	°F	- 3 3 0 ~ 7 5 0		°F	3 2 ~ 3 1 0 0

CHART 2 DISPLAY RANGE & SETTING RANGE OF R.T.D. INPUT (J I S C 1 6 0 4 - 1 9 9 7)

	Setting Range	Display Range	Setting Range (With Decimal)	Display Range (With Decimal)
Pt100	°C	- 1 9 9 ~ 5 0 0	- 1 9 9 . 9 ~ 5 0 0 . 0	- 1 9 9 . 9 ~ 5 3 9 . 1
	°F	- 1 9 9 ~ 9 5 0	- 1 9 9 . 9 ~ 9 5 0 . 0	- 1 9 9 . 9 ~ 9 9 9 . 9
JPt100	°C	- 1 9 9 ~ 5 0 0	- 1 9 9 . 9 ~ 5 0 0 . 0	- 1 9 9 . 9 ~ 5 2 9 . 1
	°F	- 1 9 9 ~ 9 5 0	- 1 9 9 . 9 ~ 9 5 0 . 0	- 1 9 9 . 9 ~ 9 8 4 . 4

CHART 3 DISPLAY RANGE & SETTING RANGE OF CURRENT

	Setting Range	Display Range
4 ~ 20mADC	- 1 9 9 9 ~ 9 9 9 9 / - 1 9 9 . 9 ~ 9 9 9 . 9 / - 1 9 . 9 9 ~ 9 9 . 9 9	Displays approx. ±12% wider then setting range.

8 . ORDERING INFORMATION

T T M - 1 0 L - - - A

Input	記号
Thermocouple / R.T.D.	0
4 ~ 20mA DC	1

Output	記号
None	N
Relay contact	R
SSR drive volt.	P

Option	記号
Communication R S - 4 8 5	M 1
Communication R S - 2 3 2 C	M 2

9 . SPECIFICATIONS

9.1 GENERAL SPECIFICATION(COMMON)

Power Supply Voltage		1 2 V D C ± 1 0 % o r 2 4 V D C ± 1 0 %			
Power Consumption		1 2 V D C : below 1 . 4 W 2 4 V D C : below 2 . 7 W			
Operation environment	Temperature & Humidity range	0 ~ 5 0 / 3 5 ~ 8 5 % R H (Avoid making dew)			
	Supply Voltage	1 2 V D C ± 1 0 % o r 2 4 V D C ± 1 0 %			
Transportation storage environment	Temperature & Humidity range	- 2 0 ~ 6 0 / 3 5 ~ 8 5 % R H (Avoid making dew)			
	Vibration Condition	0 . 5 G	Impact Condition	0 ~ 5 0 G	Package Drop test Drop from the height 60cm
Mechanical Specifications	Weight	TTM-10L less then 80 g			

9.2 GENERAL SPECIFICATION(DETAILS)

PV INPUT	Kind of INPUT	Thermocouple	K, J, E, T, N, R, S, W5Re/W26Re Switchable. Input resistance: more than 1 M Bias Current: Approx 0 . 2 μ V / Burn out: "OVER" (- - - -)		
		R . T . D .	Pt100 / JPt100 Switchable. External resistance: less than 5 (Per wire) Burn out: Shown "OVER" (- - - -) same display shown at snapping of either A, B or b.		
		CURRENT (4-20mA DC)	Input resistance: 2 5 0 Burn out: Shown "UNDER" (- - - -)		
	Sampling cycle	0 . 5 sec (same as Output alteration cycle)			
PV/Character Display	PV Display	4 figures 7 segment L C D Letter height 7 mm			
	Character Display	1 figure 7 segment L C D Letter height 5 mm			
	Control Output	OUT Lamp	Light ON at Control Output		
	Alarm Output	AL Lamp	Light ON at Alarm Output		
Indication Accuracy	Communication	COM Lamp	Light ON at operating Communication		
	Thermocouple	± 0.5% + 1digit of indicated value, or ± 4 (8°F) , (Stipulated by the standard environment and the conversion of indicated value)			
	R . T . D .	± 0.5% + 1digit of indicated value, or ± 1.2 (2.4°F) , (Stipulated by the standard environment and the conversion of indicated value)			
	CURRENT (4-20mA DC)	± 0.5% + 1digit of Setting Value Limiter Span. (Stipulated by the standard environment and the conversion of indicated value)			
Control & Output Section	Output at Special cases	All Output functions being OFF for approximately 4 seconds after Power ON. Control Output being OFF at abnormal Process Value.			
	Kind of Output and Rating	Relay Contact Output	Contact specification : 1a Contact point. Contact capacity : 250VAC 3A (Load resistance) Endurance : more than 100,000 times.		
		SSR Drive Voltage Output	Output Voltage : OFF time; 0V ON time ; 12V +10% -20% Loaded resistance : Over 600		
Alarm Functions	Alarm Output	Contact specification : 1a Contact point. Contact capacity : 250VAC 0.5A (Load resistance) or 125VAC 1A (Load resistance) Endurance : more than 100,000 times.			



Head office : 1 0 2 1 3 - 2 3 ,Tana,Sagamihara Kanagawa 229-1124 Japan.

Phone +81-42-777-3311

FAX +81-42-777-3751

(C) 1998 TOHO ELECTRONICS INC . All rights reserved .

43-0872-A